



14/23-31 McIntyre Street Gordon NSW

1  1  1 

Spacious one bedroom, Quiet, Ground floor apartment with a large courtyard.

Internally you are greeted by a combined lounge/dining flowing seamlessly to the modern kitchen featuring a gas cooktop and near new appliance surrounded by that stone benchtop. The Bedroom has mirror built-ins and is accompanied by a fully tiled luxurious bathroom. The unit has plenty of storage throughout and internal laundry. There is air-conditioning and a car space with caged storage, lift access and security intercom.

Located only 400m from Gordon shopping Centre and 650m to Gordon train station and Transport Hub. Close to some of Sydney's most prestigious schools such as Knox Grammar, Pymble Ladies College and Ravenswood, just to name a few, the unit is also within the Gordon West Public School and Killara High School Zones.

Price : \$ 672,500

View : <https://www.assetrealty.com.au/sale/nsw/north-s-hore-upper/gordon/residential/apartment/7352551>



Sima Akbarian
02 9498 7799

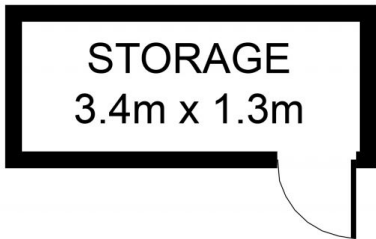
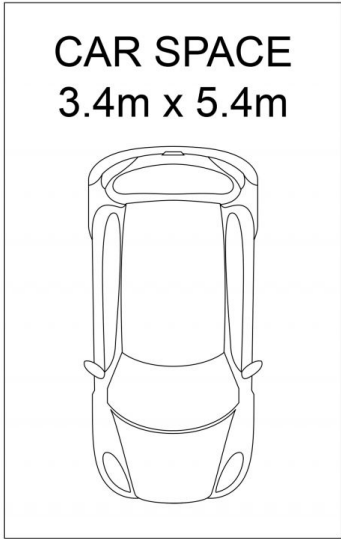
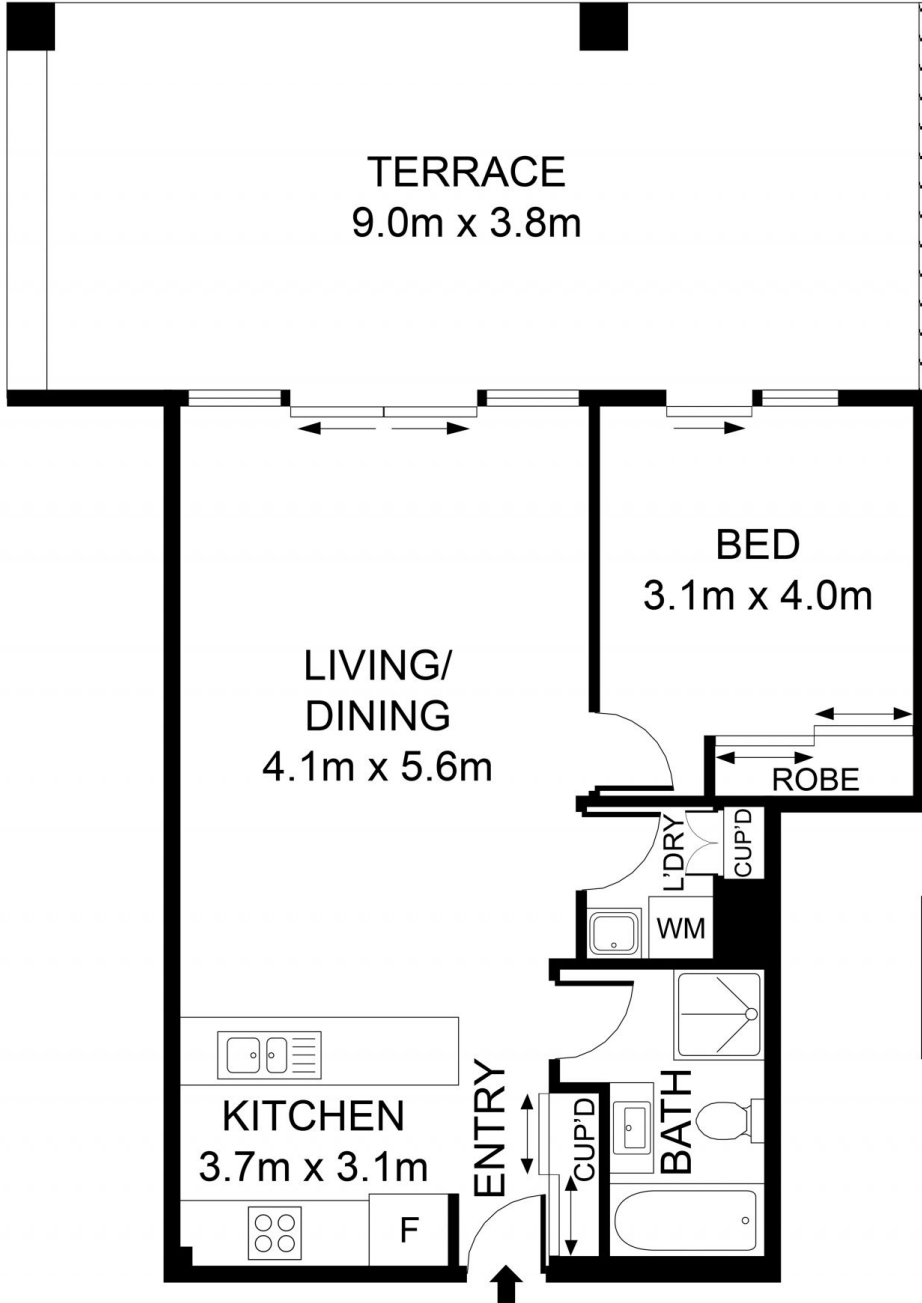

Internal Area + Courtyard: 91 sqm
 Car Space + Storage Cage: 22 sqm
 Total Area: 113 sqm

14/23 McIntyre Street, Gordon



DISCLAIMER: 3D Property View accepts no liability for the accuracy of details contained within our floor plans. All plans are drawn and also checked to the best our ability, however information contained in our floor plans such as area calculations are approximate, and have not been surveyed or drawn to scale. Our floor plans are for representational purposes only and should be used as such. Do not attempt to refer to our floor plans for structural or detailed information.